



ZNT.X

LED



ZONE 1-2 / 21-22

IP 66

$-20\text{ }^{\circ}\text{C} < T_a < +45\text{ }^{\circ}\text{C}$



included technology
SAMSUNG

Product	Aluminium Body Tank Lamp
Certification	SCA 23 ATEX 186X
Marking	II 2G Ex db IIB + H2 T6 Gb II 2D Ex tb IIIC T80°C Db.
IP	IP 66
Ambiant Temp.	-20 °C up to +45 °C
Standarts	EN60079-0: 2018; EN60079-1: 2014; EN60079-31: 2014
Cable Entries	1 x 1/2" NPT
Body	Low Cooper Aluminium Alloy
Difusser	Shock and high temperature tempered glass
Gaskets	NBR oring on covers
Paint	Electrostatic Powder Coat
Circuit	Led driver
Rated Voltage	220/240V AC - 24V DC
Frequency	47/63 Hz
Application	Oil refineries, Chemical and petrochemical plants, Boiler rooms etc.

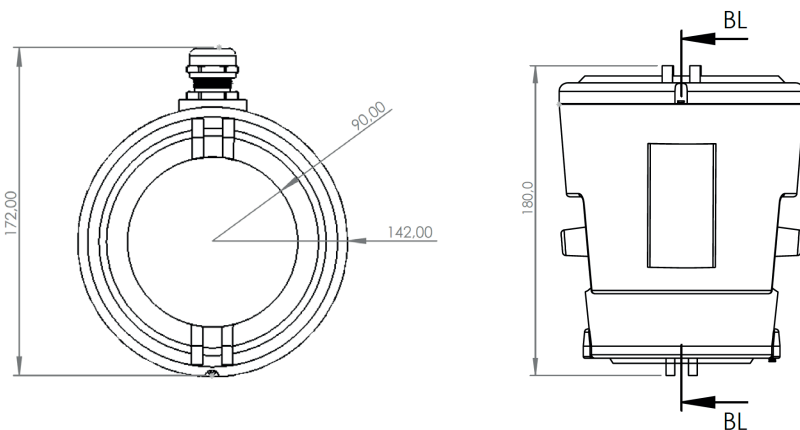

ZNT.15W

24V - DC
220V - AC